

# DSA E-Series E4000 60-bay

DSA-N6C4XA-60AT | DSX-N6D4XA-60AT





# Table of contents

<b>1</b>	<b>Safety</b>	<b>5</b>
1.1	Safety message explanation	5
1.2	Safety precautions	5
1.3	Important safety instructions	5
1.4	Warning notices	7
1.5	Caution notices	8
1.6	Notices	9
1.7	Use latest software	10
<b>2</b>	<b>Short information</b>	<b>11</b>
2.1	Parts included	11
2.2	Product registration	11
2.3	Additional equipment	12
2.4	Additional documentation	12
<b>3</b>	<b>System overview</b>	<b>13</b>
3.1	Device views	13
3.2	LED description	14
3.2.1	LEDs on the operator display panel	14
3.2.2	LEDs on the controller unit	15
3.2.3	LEDs on the I/O modules	16
3.2.4	LEDs on the drives	17
3.2.5	LEDs on the drive drawer	18
3.2.6	LEDs on the power canister	19
3.2.7	LEDs on the fan canister	19
<b>4</b>	<b>Installation</b>	<b>21</b>
4.1	Installing a 60-bay unit	21
4.2	Installing a 60-bay unit with SuperRail	22
4.2.1	Installing SuperRail to square-hole four-post rack	22
4.2.2	Installing SuperRail to round-hole four-post rack	24
4.3	Installing the drives	26
4.4	Installing the front bezel on controller units and expansion units	27
4.5	Installing the end caps on expansion units	27
4.6	Setting the unit ID using the ODP button	27
<b>5</b>	<b>Connection</b>	<b>29</b>
5.1	Connecting the expansion units	29
5.2	Connecting the controller unit to the network	30
5.3	Connecting the controller unit to the management hosts	30
5.4	Connecting the units to the power supply	31
5.5	Supported connections	32
<b>6</b>	<b>Turning on/off AC power</b>	<b>34</b>
6.1	Turning on AC power	34
6.2	Turning off AC power	34
<b>7</b>	<b>Setting up the storage system</b>	<b>35</b>
7.1	Configuring static IP addresses and network settings for management ports	35
7.2	Configuring the iSCSI ports	35
7.3	Configuring the storage system with BVMS Configuration Client	36
7.4	Configuring the storage system with Configuration Manager	36
<b>8</b>	<b>Maintenance</b>	<b>38</b>
8.1	Replacing a drive in a 60-bay unit	38

8.1.1	Preparing to replace a drive	39
8.1.2	Removing a drive	40
8.1.3	Installing a drive	41
8.1.4	After replacing a drive	42

---

# 1 Safety

## 1.1 Safety message explanation

---

**Notice!**

Indicates a situation which, if not avoided, could result in damage to the equipment or environment, or data loss.

---

**Caution!**

Indicates a hazardous situation which, if not avoided, could result in minor or moderate injury.

---

**Warning!**

Indicates a hazardous situation which, if not avoided, could result in death or serious injury.

---

## 1.2 Safety precautions

---

**Caution!**

The Low Voltage power supply unit must comply with EN/UL 60950. The power supply must be a SELV-LPS unit or a SELV - Class 2 unit (Safety Extra Low Voltage - Limited Power Source).

---

**Caution!**

Installation should only be performed by qualified service personnel in accordance with applicable local codes.

---

## 1.3 Important safety instructions

Read, follow, and retain for future reference all of the following safety instructions. Follow all warnings before operating the device.

- Unplug the unit from the outlet before cleaning. Follow any instructions provided with the unit.
- Clean only with a dry cloth. Do not use liquid cleaners or aerosol cleaners.
- Do not install device near any heat sources such as radiators, heaters, stoves, or other equipment (including amplifiers) that produce heat.
- Never spill liquid of any kind on the device.
- Take precautions to protect the device from power and lightning surges.
- Unless qualified, do not attempt to service a damaged device yourself. Refer all servicing to qualified service personnel.
- Install in accordance with the manufacturer's instructions in accordance with applicable local codes.
- Use only attachments/accessories specified by the manufacturer.
- Protect all connection cables from possible damage, particularly at connection points.
- Do not defeat the safety purpose of a polarized or ground-type plug.
- Permanently connected devices must have an external, readily operable mains plug or all-pole mains switch in accordance with installation rules.
- Pluggable devices must have an easily accessible socket-outlet installed near the equipment.

- The plug-socket combination must be accessible at all times, because it serves as the main disconnecting device.
- Any openings in the unit enclosure are provided for ventilation to prevent overheating and ensure reliable operation. Do not block or cover these openings.
- If you install this device in an enclosure, make sure the enclosure is properly ventilated according to the manufacturer's instructions.
- Install the unit only in a dry, weather-protected location.
- Do not use this unit near water, for example near a bathtub, washbowl, sink, laundry basket, in a damp or wet basement, near a swimming pool, in an outdoor installation, or in any area classified as a wet location.
- To reduce the risk of fire or electrical shock, do not expose this unit to rain or moisture.
- Never push objects of any kind into this unit through openings as they may touch dangerous voltage points or short-out parts that could result in a fire or electrical shock.
- Power supply cords should be routed so that they are not likely to be walked on or pinched by items placed upon or against them, paying particular attention to cords and plugs, convenience receptacles, and the point where they exit from the appliance.
- Operate the unit only from the type of power source indicated on the label. Use only the power supply provided or power supply units with UL approval and a power output according to LPS or NEC Class 2.
- Do not open or remove the cover to service this unit yourself. Opening or removing covers may expose you to dangerous voltage or other hazards. Refer all servicing to qualified service personnel.
- Be sure the service technician uses replacement parts specified by the manufacturer. Unauthorized substitutions could void the warranty and cause fire, electrical shock, or other hazards.
- Do safety inspections after service or repairs to the device to make sure the device operates properly.
- Observe the relevant electrical engineering regulations.
- When installing in a switch cabinet, ensure that the unit and the power supply units have sufficient grounding.
- Connect the unit to an earthed mains socket.
- Use proper CMOS/MOS-FET handling precautions to avoid electrostatic discharge (ESD).
- For protection of the device, the branch circuit protection must be secured with a maximum fuse rating of 16 A. This must be in accordance with NEC800 (CEC Section 60).
- Disconnect the power before moving the unit. Move the unit with care. Excessive force or shock may damage the unit and the hard disk drives.
- All the input/output ports are Safety Extra Low Voltage (SELV) circuits. SELV circuits should only be connected to other SELV circuits.
- If safe operation of the unit cannot be ensured, remove it from service and secure it to prevent unauthorized operation.
- Disconnect power supply and arrange for the device to be serviced by qualified personnel in the following cases, because safe operation is no longer possible:
  - The power cable/plug is damaged.
  - Liquids or foreign bodies have entered the device.
  - The device has been exposed to water or extreme environmental conditions.
  - The device is faulty despite correct installation/operation.
  - The device has fallen from a height, or the housing has been damaged.
  - The device was stored over a long period under adverse conditions.
  - The device performance is noticeably changed.

- Installation of the unit must comply with local and national electrical codes.
- Cluster media converters must be installed in a restricted access location.
- When installing the unit into a movable cabinet or rack, install from the bottom up for best stability.
- Use only manufacturer's supplied power cords and cables with manufacturer equipment.
- DC-based systems must be installed in a restricted access location and the two input power terminals for the DC power supply must be connected to separate isolated branch circuits.
- A qualified service person is required to make the DC power connection according to local and national electric codes / guidelines.
- Ensure your DC mains supply is earthed at the point of generation per IEC 60950-1.
- To reduce the risk of personal injury or equipment damage, allow internal components time to cool before touching them.
- Ensure that the equipment is properly supported or braced when installing options.
- This equipment is designed for connection to a grounded outlet. The grounding type plug is an important safety feature. To avoid the risk of electrical shock or damage to the equipment, do not disable this feature.
- Risk of electrical shock - If there is evidence of fire, water, or structural damage, never turn on the power to the equipment.
- Risk of electrical shock - Before removing or installing a power supply, turn off the power switch, and unplug the power cord.
- Pinching hazard - As you push the canister into the slot, ensure that your fingers are not pinched between the lever and the canister. The lever automatically moves toward the closed position as the canister is pushed into its slot.
- Do not remove more than one canister from the enclosure while power to the enclosure is turned on.
- Our products may contain Class 1 laser devices, Class 1M laser devices, or both.
- Keep away from moving fan blades.
- Do not use equipment in the cabinet as a shelf or work space.

## 1.4 Warning notices

This product relies on the building's installation for short-circuit (overcurrent) protection. Ensure that a fuse or circuit breaker no larger than 120 VAC, 20A U.S. (240 VAC, 16A international) is used on the phase conductors (all current-carrying conductors).

**Warning!**

High leakage current. Earth connection essential before connecting supply.

**Warning!**

To prevent personal injury or damage to the unit, never attempt to lift or tilt the unit using the handles of controller modules, power supplies, fans, and so on. These types of handles are not designed to support the weight of the unit.

**Warning!**

An electrical outlet that is not correctly wired could place hazardous voltage on metal parts of the system or the devices that attach to that system. It is the customer's responsibility to ensure that the outlet is correctly wired and grounded to prevent an electrical shock.

**Warning!**

To prevent electrical shock hazard, disconnect all power cables from the electrical outlet before relocating the system.

**Warning!**

Risk of bodily injury, A lead-acid battery can weigh up to 10.9kg (24.1lb). When you remove this type of battery, be prepared to support its weight. If the battery is dropped, the impact might cause bodily injury, including deep puncture wounds caused by the battery pins.

**Warning!**

For Class 1M laser products

Laser radiation. Do not view directly with optical instruments. Viewing the laser output with certain optical instruments (for example, eye loupes, magnifiers, and microscopes) within a distance of 100 mm might pose an eye hazard. Use of controls or adjustments or performance of procedures other than those specified herein might result in hazardous radiation exposure. Do not disassemble or remove any part of a small form-factor pluggable (SFP) transceiver because you might be exposed to laser radiation.

**1.5****Caution notices****Caution!**

The battery used in this device might present a risk of fire, explosion, or chemical burn if mistreated. DO NOT crush or puncture, short circuit external contacts, disassemble, dispose of in fire or water, heat above maximum temperature limit, or incinerate.

**Caution!**

DOUBLE POLE/NEUTRAL FUSING

**Caution!**

To avoid personal injury, before lifting this unit, remove all appropriate subassemblies per instructions to reduce the system weight.

**Caution!**

Equipment weighing less than 18 kg (39.7 lbs) can be lifted by one person.

Equipment weighing equal to or more than 18 kg (39.7 lbs) and less than 32 kg (70.5 lbs) requires two people to lift.

Equipment weighing equal to or more than 32 kg (70.5 lbs) and less than 55 kg (121.2 lbs) requires three people to lift.

Equipment weighing equal to or more than 55 kg (121.2 lbs) and less than 72 kg (158.7 lbs) requires four people to lift.

Equipment weighing equal to or more than 72 kg (158.7 lbs) requires a lifting device.

## 1.6 Notices



**Notice!**

This is a **class A** product. In a domestic environment this product may cause radio interference, in which case the user may be required to take adequate measures.



**Notice!**

Video loss is inherent to digital video recording; therefore, we cannot be held liable for any damage that results from missing video information.

To minimize the risk of losing information, we recommend multiple, redundant recording systems, and a procedure to back up all analog and digital information.

### Old electrical and electronic equipment

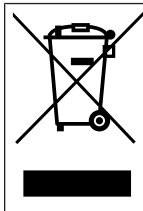

This product and/or battery must be disposed of separately from household waste. Dispose such equipment according to local laws and regulations, to allow their reuse and/or recycling. This will help in conserving resources, and in protecting human health and the environment.



**Notice!**

Do not dispose batteries in household waste. Dispose of batteries only at suitable collection points and, in the case of lithium batteries, mask the poles.



**Caution!**

**Battery replacement - For qualified service personnel only**

A lithium battery is located inside the unit enclosure. To avoid danger of explosion, replace the battery as per instructions. Replace only with the same or equivalent type recommended by the manufacturer. Dispose of the replaced battery in an environmentally friendly way and not with other solid waste. Refer all servicing to qualified service personnel.



Do not place this unit on an unstable stand, tripod, bracket, or mount. The unit may fall, causing serious injury and/or serious damage to the unit.

### Information on sales, delivery, storage, and working life period

If used for the specified purpose in compliance with the safety instructions and technical specifications, the working life period of the product is in accordance with normal expectations for this type of product.

### Information on equipment use

Device is for professional installation only. Operation of the devices is not intended for personal or household use. There are no restrictions to use the device in commercial and industrial areas, except those mentioned in the Safety information.

## 1.7

### Use latest software

Before operating the device for the first time, make sure that you install the latest applicable release of your software version. For consistent functionality, compatibility, performance, and security, regularly update the software throughout the operational life of the device. Follow the instructions in the product documentation regarding software updates.

## 2 Short information

### 2.1 Parts included

Make sure that all parts are included and not damaged. If the packaging or any parts are damaged, contact your shipper. If any parts are missing, contact your Sales or Customer Service Representative.

#### Dual controller units

Quantity	Component
1	DSA E4000 60-bay dual controller (empty enclosure)
6	Set of 10 hard disks
1	Installation manual
1	Rack mount kit (set of 2 rails)
1	Plastic front bezel
2	Power cable C19 - C20
1	Diagnostic cable

#### Expansion units

Quantity	Component
1	DSA E4000 60-bay expansion unit (empty enclosure)
6	Set of 10 hard disks
1	Installation manual
1	Rack mount kit (set of 2 rails)
1	Plastic front bezel
2	Power cable C19 - C20
4	Mini SAS HD to Mini SAS HD cable (1 m)

### 2.2 Product registration

We recommend that you register your device. If you already have an existing NetApp NOW account, add your device to it. If you have no NetApp NOW account, create a new account using the product registration page.

#### Registering your device using an existing NetApp NOW account

Sign in to your NetApp NOW account and register your device.

#### Creating a new account using the product registration page

Register your product under:

<https://www.iqsight.com/en/support/after-sales-services/product-registration/>



## 2.3 Additional equipment

You may need the following equipment:

- A Phillips No. 2 and a medium flat-blade screwdriver
- An ESD wrist strap
- An Ethernet switch or network hub
- Ethernet cables
- Management station or personal computer

## 2.4 Additional documentation

### More information

For more information, software downloads, and documentation, go to [www.iqsight.com](http://www.iqsight.com) and the corresponding product page.

### 3 System overview

#### 3.1 Device views

60-bay dual controller unit or expansion unit - front view



1	7-segment display	2	Power LED
3	Attention LED	4	Locate LED
5	Drive canister		

60-bay dual controller unit - rear view

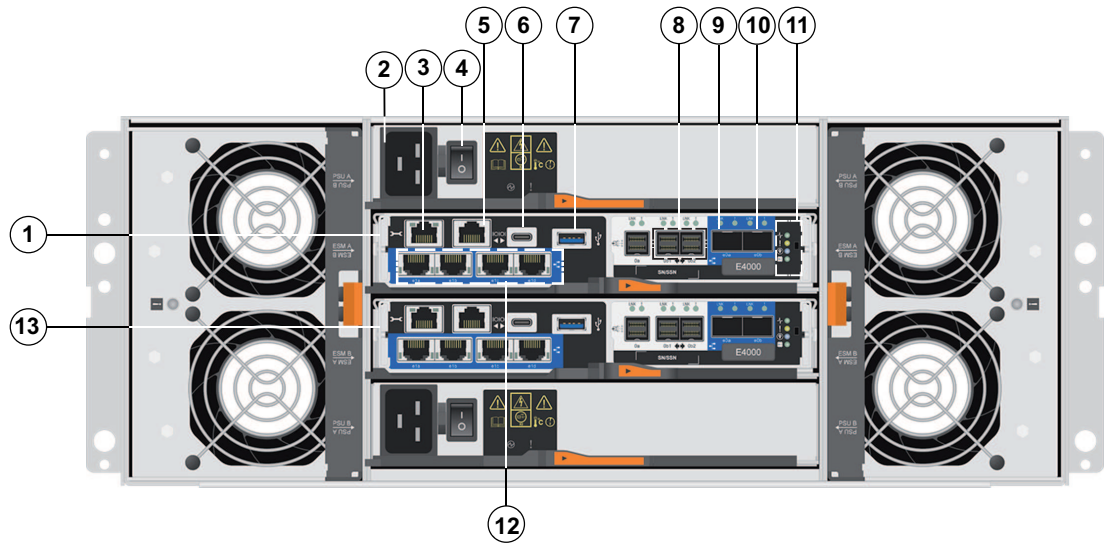

1	Controller A	2	Mains connection 240 VAC
3	Management port e0m/BMC	4	On/off switch
5	Serial port (not used)	6	USB-C serial com port (non-production use only)
7	USB-A port	8	SAS expansion ports 0b1/0b2
9	Optical port e0a	10	Optical port e0b
11	Status LEDs	12	iSCSI Base-T ports e1a, e1b, e1c, e1d (Do not use e1c and e1d!)

13	Controller B (see Controller A)		
----	---------------------------------	--	--

**60-bay expansion unit - rear view**

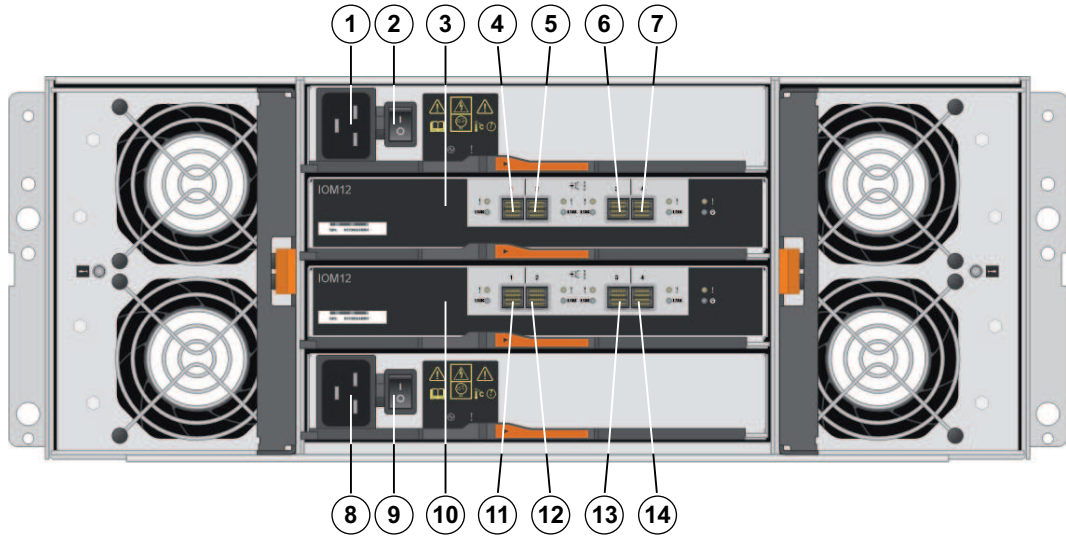

1	Mains connection 240 VAC	2	On/off switch
3	IOM A	4	IOM A - SAS port 1
5	IOM A - SAS port 2	6	IOM A - SAS port 3
7	IOM A - SAS port 4	8	Mains connection 100 - 240 VAC
9	On/off switch	10	IOM B
11	IOM B - SAS port 1	12	IOM B - SAS port 2
13	IOM B - SAS port 3	14	IOM B - SAS port 4

### 3.2 LED description

There are several LEDs on the front and rear of the chassis. The LEDs show the over-all status of the system and the activity and health of specific components.

#### 3.2.1 LEDs on the operator display panel

Each controller unit and expansion unit has LEDs located on the operator display panel. The operator display panel is visible through the front bezel of a controller unit and through the left end cap of an expansion unit.



1	Power LED	2	Attention LED
3	Location LED		

The following table describes the LEDs and their operational states:

LED	LED icon	Status indicator	Description
Power		On green	At least one of the two PSUs is delivering power to the system.
		Off	Neither PSU is delivering power to the system.
Attention		On amber	The system halted or a fault occurred in the chassis.
		Off	The system is operating normally.
Location		On or flashing blue	The LED has been manually activated to aid in physically locating equipment
		Off	The LED has not been manually activated to aid in physically locating equipment

### 3.2.2

#### LEDs on the controller unit

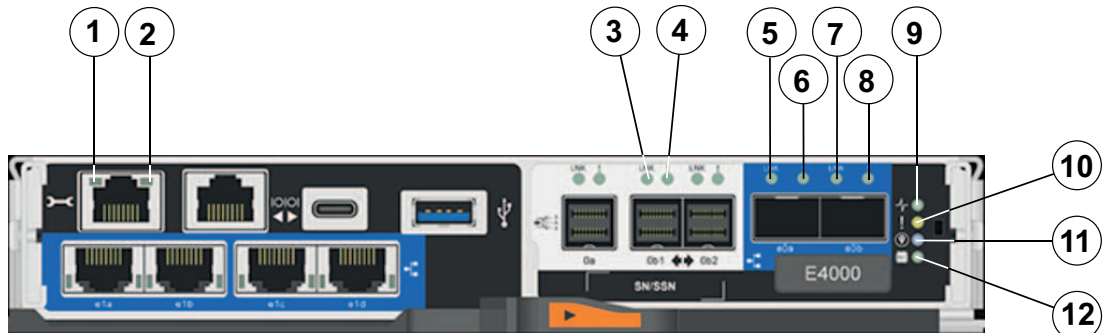

The back of the controller unit includes LEDs that indicate the status of the controller. For example, the controller is active, the controller needs attention, or when there is Ethernet activity.



1	Ethernet port Link (left)	2	Ethernet port Activity (right)
3	SAS port Link	4	SAS port attention
5	Ethernet port Link	6	Ethernet port Attention
7	Ethernet port Link	8	Ethernet port Attention
9	Controller Activity LED	10	Controller Attention LED
11	Chassis Locate LED	12	Cache Active LED

The following table describes the LEDs and their operational states:

LED	LED icon	Type	Status indicator	Description
0b1		Attention	Yellow	SAS link requires attention

LED	LED icon	Type	Status indicator	Description
Port SAS 2 LED Onboard Config			Off	SAS link operates as normal
		Link	Green	Link is established on at least one external SAS lane
			Off	No link is established on any external SAS lane
e0a Port Ethernet SFP Config		Attention	Yellow	Ethernet Port requires attention.
			Off	Ethernet port operates as normal
		Link	Green	A connection is established to the port.
			Off	No connection is established on the port.
e0b Port Ethernet SFP Config		Attention	Yellow	Ethernet Port requires attention.
			Off	Ethernet port operates as normal
		Link	Green	A connection is established to the port.
			Off	No connection is established on the port.
e0m/BMC Ethernet On/Off		Port Activity	Blinking green	Traffic is present on the active link
			Off	Off
		Port Link	Solid green	On
			Off	No link established

### 3.2.3

#### LEDs on the I/O modules

The I/O module (IOM) includes the SAS ports for connecting the expansion units to the controller units or to other expansion units.

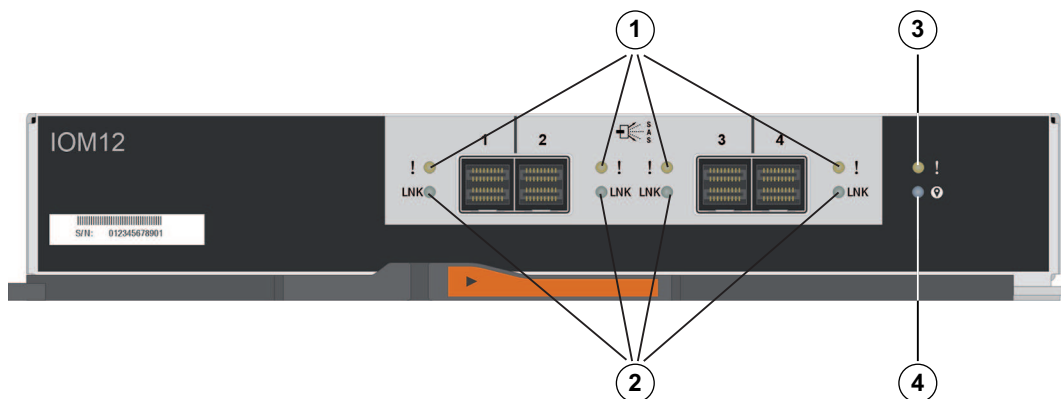

1	SAS port attention LED	2	SAS port link LED
3	IOM attention LED	4	IOM locate LED

The following table describes the LEDs and their operational states:

LED	Status indicator	Description
Attention	Amber	The IOM is not functioning correctly.
	Off	The IOM is functioning correctly.
Locate	Blue	There is an active request to physically locate the expansion unit. <b>Note:</b> When the <b>Locate</b> LED is activated, the <b>Locate</b> LED on the left end cap of the expansion unit is also activated. The <b>Locate</b> LEDs turn off automatically after 30 minutes.
	Off	There is no active request to locate the expansion unit.
SAS port link	Green	The SAS port established a link (with either a controller or another expansion unit).
	Off	No link is established to another SAS port.
SAS port attention	Amber	One or more of the links in the port are not working properly.
	Off	The port is optimal and no link error has occurred.

### 3.2.4 LEDs on the drives

The drives that are installed in the controller unit and the expansion unit include an Activity LED and an Attention LED.



1	Activity LED	2	Attention LED
---	--------------	---	---------------

The following table describes the LEDs and their operational states:

LED	Status indicator	Description
Activity	Green	The drive has power.
	Blinking green	The drive has power, and I/O is in process.
Attention	Amber	An error occurred with the functioning of the drive.

### 3.2.5

#### LEDs on the drive drawer

Each of the 5 drive drawers in the 60-bay controller unit and the 60-bay expansion unit includes a single Attention/Locate LED for the unit and 12 Activity LEDs for the drives.

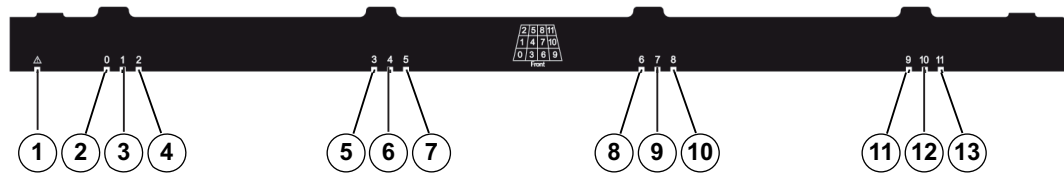

<b>1</b>	Attention/Locate LED	<b>2-13</b>	Activity LEDs
----------	----------------------	-------------	---------------

The following table describes the LEDs and their operational states:

LED	Status indicator	Description
Attention/Locate LED	Amber	The drawer or a drive in the drawer requires operator attention.
	Off	The drawer and all drives in the drawer are operating normally.
	Blinking	A locate operation for a drive in the drawer is in progress.
Activity LEDs (for drives 0 through 11 in the drive drawer)	Green	The power is turned on and the drive is operating normally.
	Off	The power is turned off.
	Blinking	Drive I/O activity is taking place.

Within a drive drawer, there are 12 drive slots numbered 0 through 11. Each drive uses an amber Attention LED that comes on if the drive requires operator attention

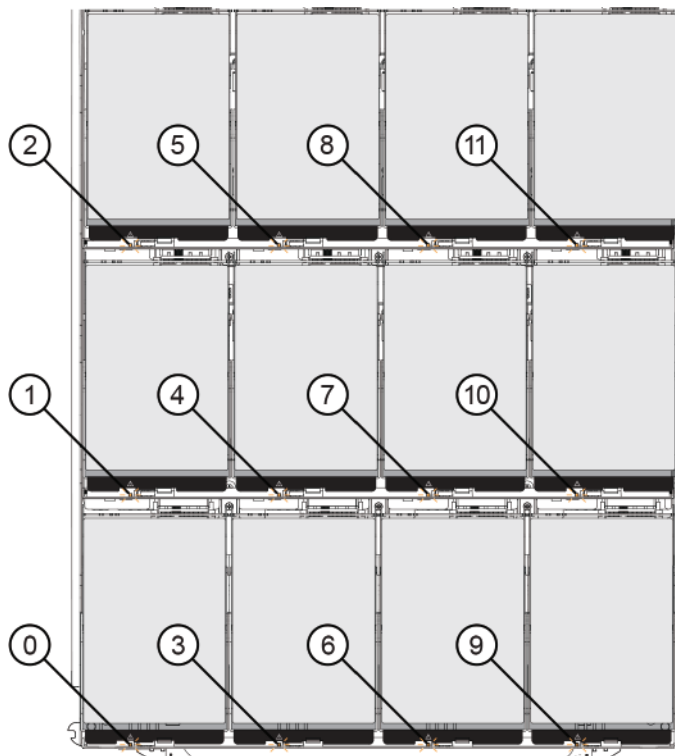

0	Attention/Locate drive LED 0	1	Attention/Locate drive LED 1
2	Attention/Locate drive LED 2	3	Attention/Locate drive LED 3
4	Attention/Locate drive LED 4	5	Attention/Locate drive LED 5
6	Attention/Locate drive LED 6	7	Attention/Locate drive LED 7
8	Attention/Locate drive LED 8	9	Attention/Locate drive LED 9
10	Attention/Locate drive LED 10	11	Attention/Locate drive LED 11

The LED status of the drives are indicated as follows:

- **Amber:** The drive in the drawer requires operator attention.
- **Off:** The drive in the drawer is operating normally.
- **Blinking:** A locate operation for the drive is in progress.

### 3.2.6 LEDs on the power canister

The power canister has LEDs and its own power switch and power outlet. Each 60-bay controller unit and 60-bay expansion unit contains two power canisters.

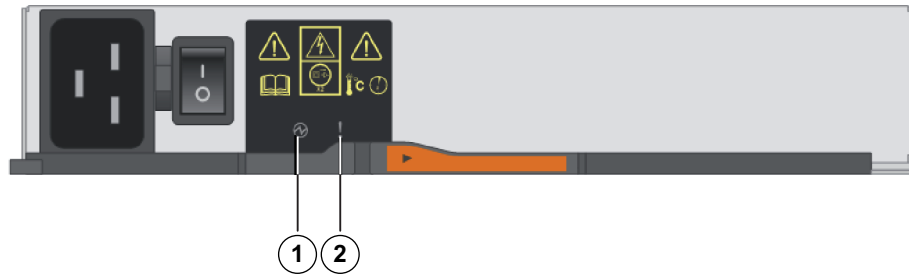

1	Power LED	2	Attention LED
---	-----------	---	---------------

The following table describes the LEDs and their operational states:

LED icon	LED name	Status indicator	Description
⚡	Power	Steady green	The power supply is functioning correctly.
		Off	The power supply failed, the AC switch is turned off, the AC power cord is not properly installed, or the AC power cord input voltage is not within margin (there is a problem at the source end of the AC power cord).
!	Attention	Steady amber	The power supply or its integrated fan has a fault.

### 3.2.7 LEDs on the fan canister

The fan canister has an Attention LED that is identified by a sideways exclamation point in the middle of the canister. Each 60-bay controller unit and 60-expansion unit has two fan canisters, one on either side of the enclosure.

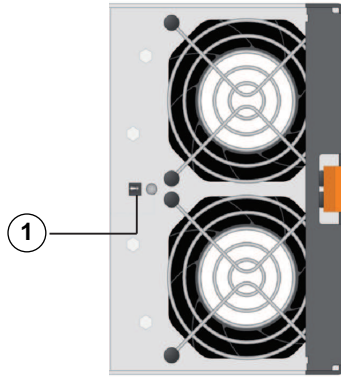

<b>1</b>	Attention LED Solid amber: The fan is faulty.
----------	--

## 4 Installation

### 4.1 Installing a 60-bay unit

You can install the unit in a four-post rack or system cabinet.

Observe the following:

- You can install the unit in either a square-hole or round-hole rack.
- Ensure that the rack is adequate for the weight and size of the unit to be installed.
- Calculate the thermal output of your equipment and compare the results with the target system cabinet's thermal rating. You might need to remove the system cabinet doors to improve airflow through the system cabinet.

For thermal rating information refer to the rack or system cabinet manuals provided by the manufacturer.

- You must use only the screws that are provided in the kit.



**Notice!**

When installing the units, load the cabinet so as not to make it top-heavy. One approach is to place the controller-unit in the middle portion of the cabinet while allowing room for expansion units to be placed above and below the controller unit.

To install a 60-bay controller unit or expansion unit:

1. If you are lifting and moving the unit by hand, attach the four handles. Push up on each handle until it clicks into place.

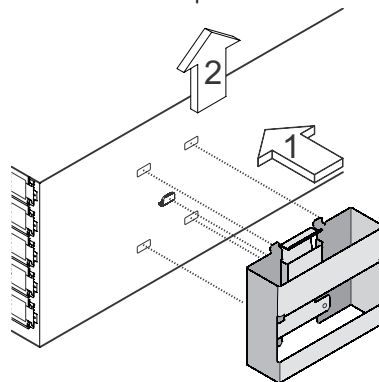

2. Place the back of the unit (the end with the connectors) on the rails.
 

**Caution:** An empty unit weighs approximately 60 kg (132 lbs). Four persons are required to safely move an empty unit. A fully loaded unit weighs approximately 113 kg (250 lbs). A mechanical lift is required to safely move the unit.
3. Supporting the unit from the bottom, slide the unit into the cabinet. If you are using the handles, use the thumb latches to detach the handles as you slide the unit in.

- Secure the unit to the front of the cabinet by inserting two screws in the 1st and 3rd holes (counting down from the top) on each side.

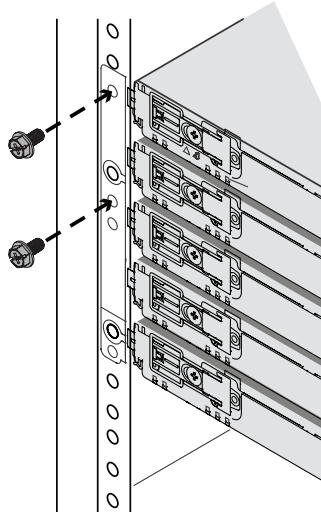

## 4.2 Installing a 60-bay unit with SuperRail

### 4.2.1 Installing SuperRail to square-hole four-post rack

Scope of delivery: SuperRail for square-hole four-post rack

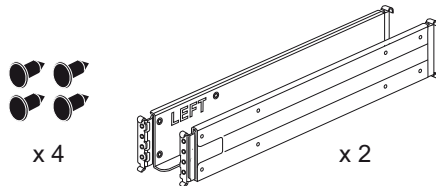

To install SuperRail to square-hole four-post rack:

- Determine where you want to install the unit in the rack or system cabinet.
 

**Note:** Whenever possible, install the units from the bottom of the rack up, so that you can use the units underneath as a guide for installing the next set of rails.
- Attach the rails to the rack or system cabinet as follows:
  - Hook in the left rail in the adapter brackets and tighten all screws completely to hold the rail firmly in place.
  - Repeat this step for the right rail.

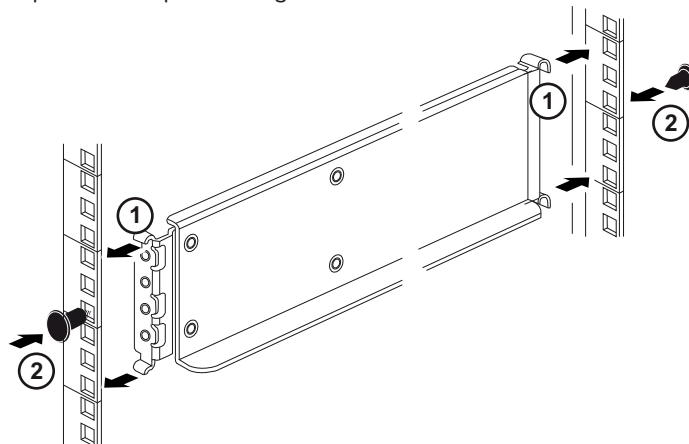

- Place the back of the unit (the end with the connectors) on the rails.

**Caution:** An empty unit weighs approximately 60 kg (132 lbs). Four persons are required to safely move an empty unit. A fully loaded unit weighs approximately 113 kg (250 lbs). A mechanical lift is required to safely move the unit.

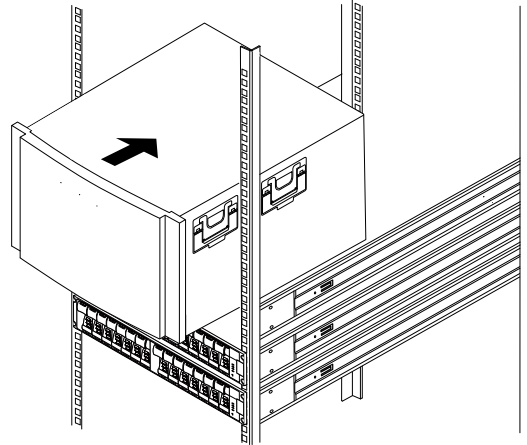

- Carefully slide the unit all the way onto the rails.  
**Note:** If applicable, you might need to remove the end caps or the system bezel to secure the unit to the rack post. Replace the system bezel when you are done.  
**Note:** Do not place additional equipment on the rails after you finish installing the unit. The rails are not designed to bear additional weight.
- For both front rail posts: Secure the unit to the front of the rack or system cabinet and rails by inserting the screws through the holes of the unit, the holes on the rack or system cabinet, and the holes on the front of rails.

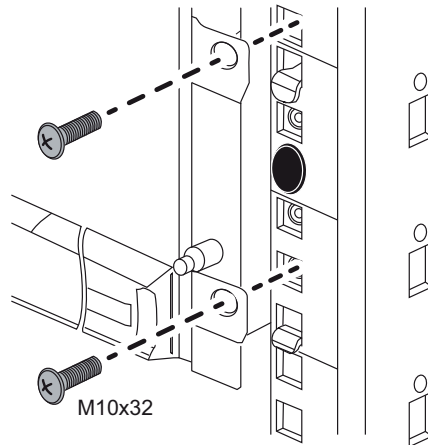

- For both rear rail posts: Secure the unit to the rear of the rack or system cabinet and rails by inserting the screws through the hole of the unit, the hole on the rack or system cabinet, and the hole on the front of rails.

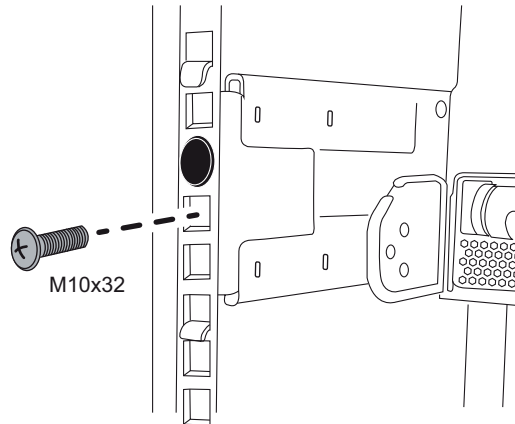

- If applicable, replace the end caps or the system bezel.

## 4.2.2

### Installing SuperRail to round-hole four-post rack

When installing SuperRail on a standard round-hole four-post rack you must use the 4 round-to-square hole adapter brackets.

Scope of delivery: SuperRail for round-hole four-post rack

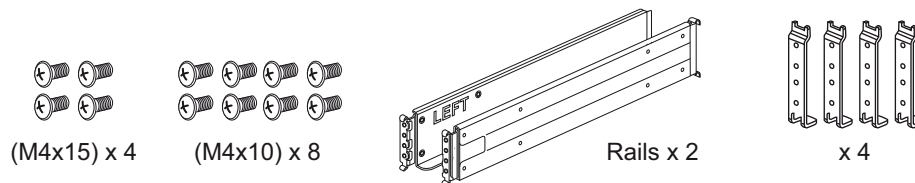

To install SuperRail to round-hole four-post rack:

- Determine where you want to install the unit in the rack or system cabinet.
 

**Note:** Whenever possible, install the units from the bottom of the rack up, so that you can use the units underneath as a guide for installing the next set of rails.
- Tighten the round-to-square hole adapter brackets with the screws to the four rack posts. Leave enough room for the hook-piece of the rail between the rail adapters and the rack posts.

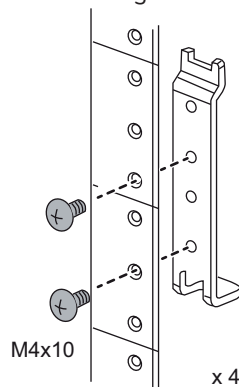

- Attach the rails to the rack or system cabinet as follows:
  - Hook in the left rail in the adapter brackets and tighten all screws completely to hold the rail firmly in place.

- Repeat this step for the right rail.

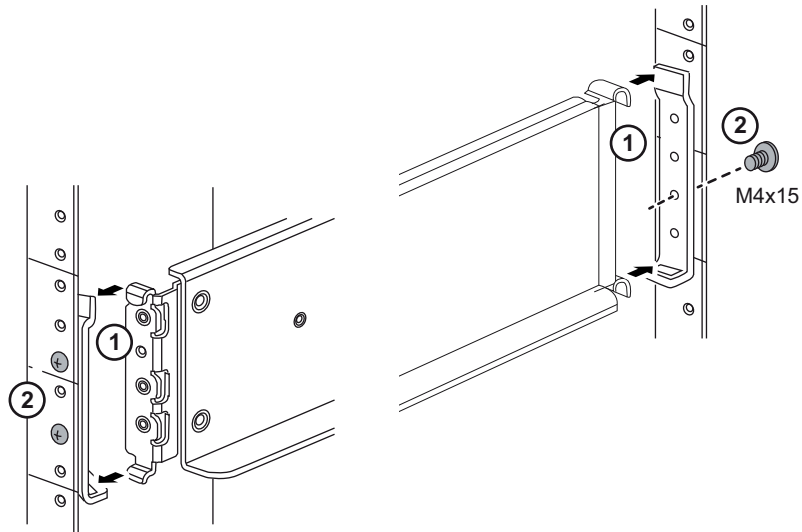

4. Place the back of the unit (the end with the connectors) on the rails.  
**Caution:** An empty unit weighs approximately 60 kg (132 lbs). Four persons are required to safely move an empty unit. A fully loaded unit weighs approximately 113 kg (250 lbs). A mechanical lift is required to safely move the unit.

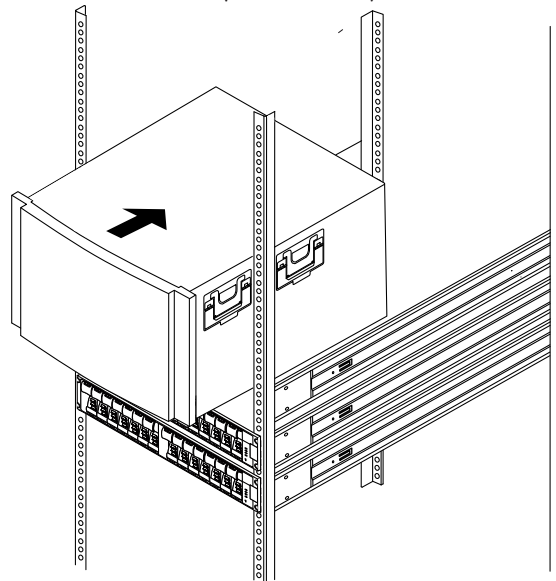

5. Carefully slide the unit all the way onto the rails.  
**Note:** If applicable, you might need to remove the end caps or the system bezel to secure the unit to the rack post. Replace the system bezel when you are done.  
**Note:** Do not place additional equipment on the rails after you finish installing the unit. The rails are not designed to bear additional weight.

- For both front rail posts: Secure the unit to the front of the rack or system cabinet and rails by inserting the screws through the holes of the unit, the holes of the mounting brackets, the holes on the rack or system cabinet, and the holes on the front of rails.

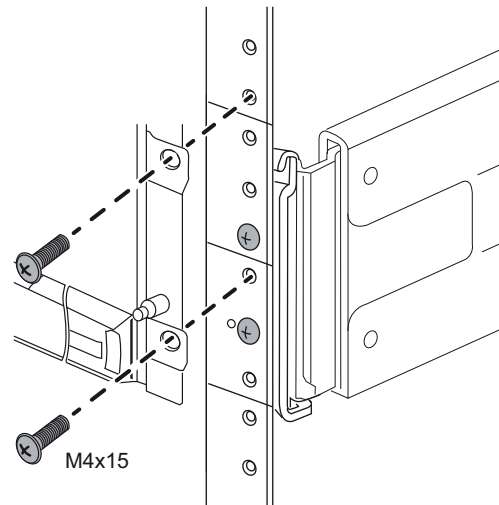

- If applicable, replace the end caps or the system bezel.

### 4.3 Installing the drives



**Notice!**

To avoid damaging the hardware, never move a unit if drives are installed. Remove all drives before moving the unit.

To install the drives:

- Put on the ESD wristband to protect the drives from static electricity.
- Release the levers on the top drive drawer. Then, slide the drawer out by using the levers.
- Raise the handle on the drive to vertical.

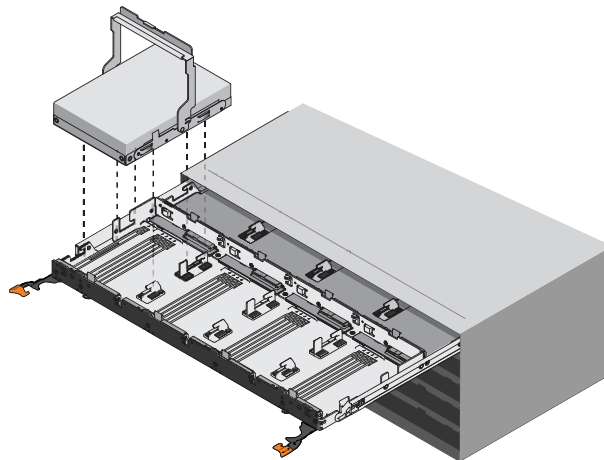

- Starting with the leftmost slot at the front, align the two raised buttons on the drive with the notches on the drawer. Then, pressing gently on the top of the drive, rotate the drive handle down until the drive snaps into place.

5. Install the remaining drives. Observe the following if you are installing fewer than 60 drives: Install drives in the front four slots of each drawer (a minimum of 20 drives in each unit) to maintain adequate airflow for cooling.
  - Distribute any remaining drives across the drawers. If possible, install an equal number of each type of drive in each drawer to allow for the creation of Drawer Loss Protected volume groups or disk pools.
6. Slide the drawer back in by sliding it from the center and closing both levers gently.
7. Attach the bezel to the front of the unit.

## 4.4 Installing the front bezel on controller units and expansion units

A front bezel covers the front of the controller unit and an expansion unit.

To install the front bezel:

1. Position the front bezel in front of the controller unit or the expansion unit, so that the holes at each end align with the fasteners on the unit.
2. Snap the bezel into place.

## 4.5 Installing the end caps on expansion units

Left and right end caps cover the mounting flanges on each expansion unit.

To install the end caps:

1. Position the left end cap in front of the expansion unit so that the holes in the end cap align with the fasteners on the left side of the unit.
2. Snap the end cap into place.
3. Repeat these steps for the right end cap.

## 4.6 Setting the unit ID using the ODP button

You can set or change the unit ID for a controller unit or a expansion unit by using the operator display panel (ODP) button.

### Before you begin

You might need to remove the front bezel or the end cap to see the ODP button.

### About this procedure

The following figure shows the operator display panel (ODP) button on the controller unit and the expansion unit.



<b>1</b>	Operator display panel (ODP) button
----------	-------------------------------------

To set the unit ID with the ODP button:

1. Turn on the unit.
2. Press and hold the ODP button until the first number on the seven-segment display starts to blink.  
**Note:** It can take up to three seconds for the number to blink. If the number does not blink in this time, release the button and press it again. Make sure to press the button all the way in.
3. Change the first number of the unit ID by repeatedly pressing the ODP button to advance the number until you reach the desired number from 0 to 9.  
 The first number continues to blink.
4. Press and hold the ODP button until the second number on the digital display starts to blink.  
**Note:** It can take up to three seconds for the second number to blink. The first number on the seven-segment display stops blinking.
5. Change the second number of the unit ID by repeatedly pressing the ODP button to advance the number until you reach the desired number from 0 to 9.  
 The second number continues to blink.
6. Lock in the desired number, and exit the programming mode by pressing and holding the ODP button until the second number stops blinking.  
**Note:** It can take up to three seconds for the second number to stop blinking.

# 5 Connection

## 5.1 Connecting the expansion units

The expansion units are shipped with the appropriate number of SAS cables.

To connect the components:

- ▶ Connect the SAS cable from the SAS port on the controller unit to the SAS port on the expansion unit.



**Notice!**

You can connect a 60-bay DSA E4000 controller unit to a maximum of four 60-bay DSA E4000 expansion units.

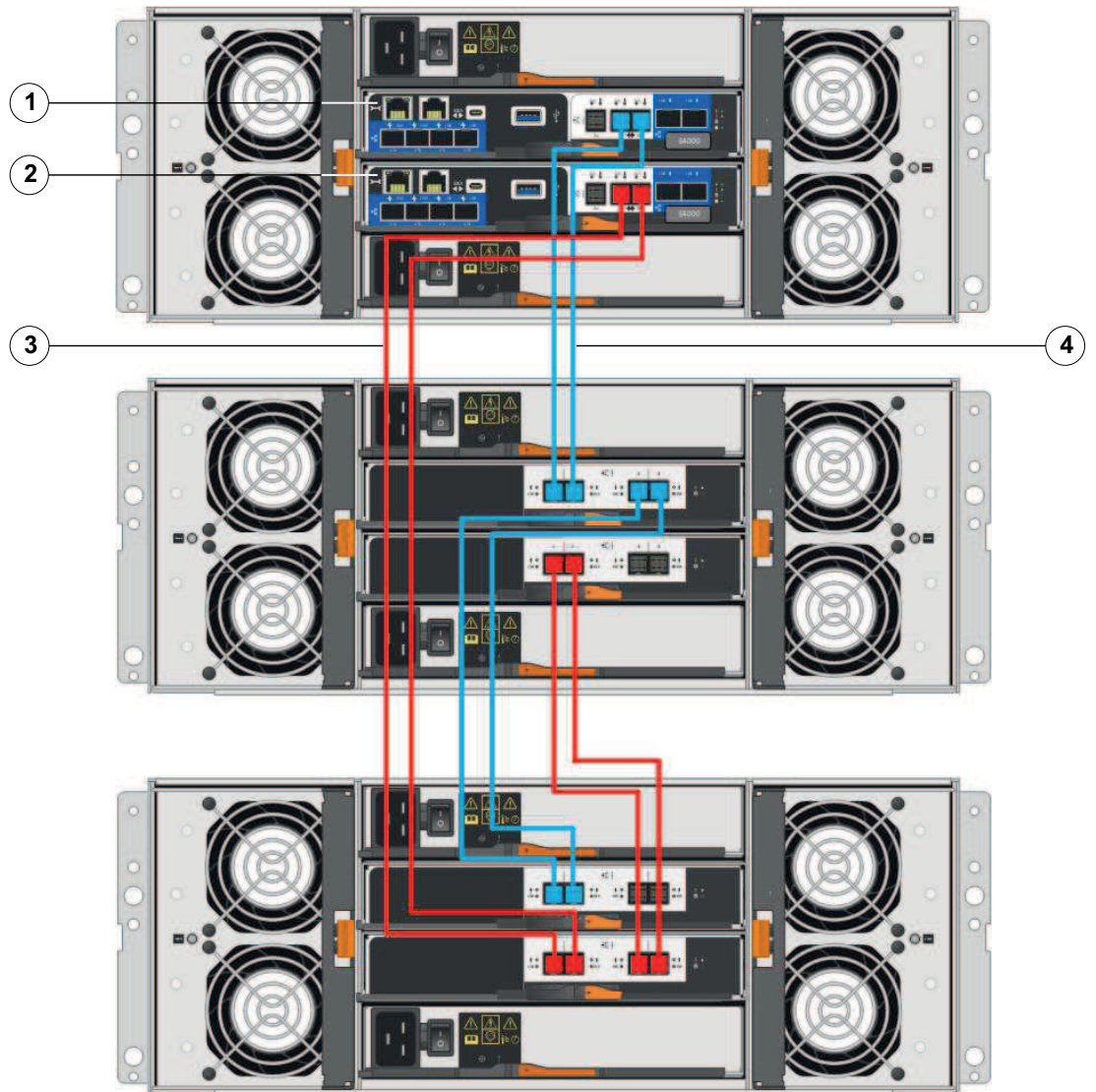

1	Controller A	2	Controller B
3	Controller A connection	4	Controller B connection

## 5.2 Connecting the controller unit to the network

In case that you use our Video Recording Solution, a host is an IP camera. To connect the controller unit to the Ethernet one or two of two available iSCSI host ports must be connected to the Ethernet. The iSCSI port connections will then be used by the IP cameras for video data traffic.

To connect the controller unit to the network:

- ▶ Connect the cable from the iSCSI host port of the controller unit to a port on the switch.
  - Note:** Make sure that the iSCSI ports of the controller unit and the relevant IP camera ports are in the same range on the switch.

### Switch topology

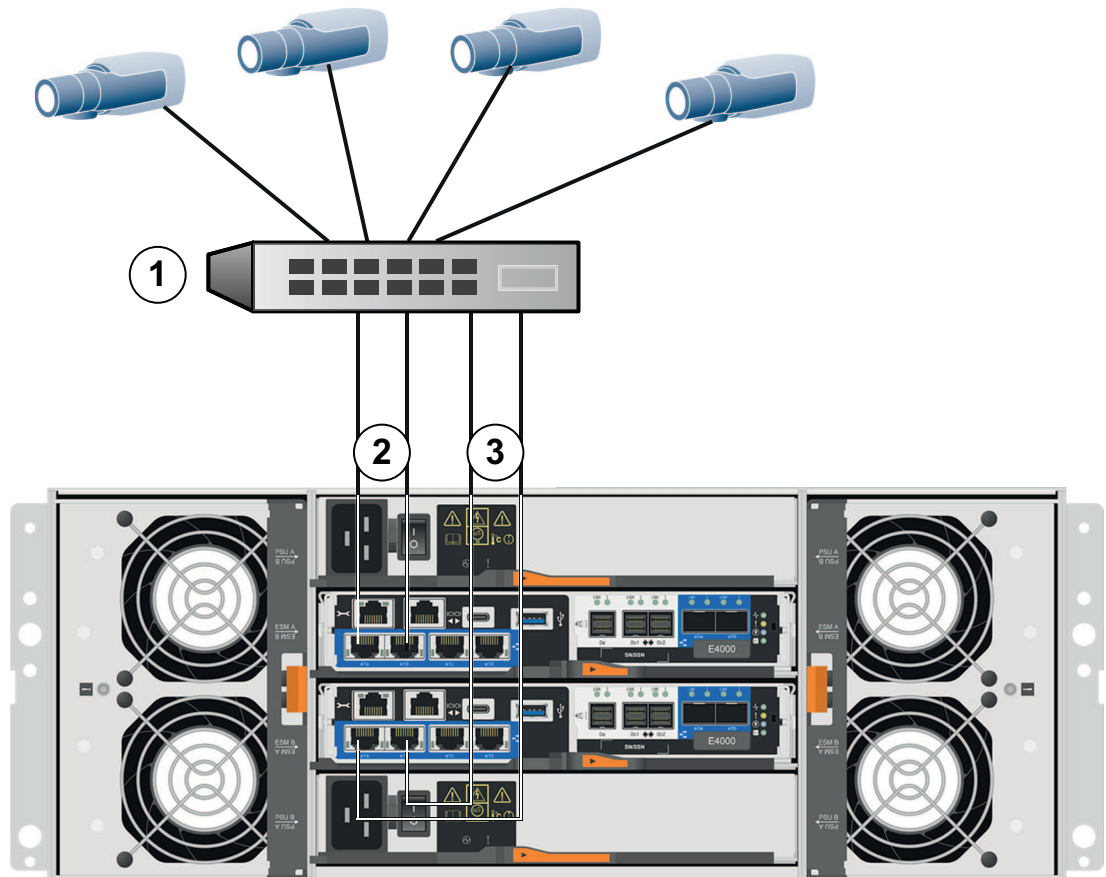

1	Switch	2	Controller A - iSCSI host interface ports (RJ45 Base-T) <b>Note:</b> Optionally, use the optical host interface ports.
3	Controller B - iSCSI host ports (RJ45 Base-T) <b>Note:</b> Optionally, use the optical host interface ports.		

## 5.3 Connecting the controller unit to the management hosts

The management host directly manages storage arrays over an out-of-band network. This section describes how to set up an out-of-band connection between the Ethernet port of a controller unit and the management host.

To set up an out-of-band connection:

1. Connect Ethernet cables between Management port e0m/BMC of controller A and Management port e0m/BMC of controller B to an external Ethernet switch or hub.
2. Connect the management host to the Ethernet switch or hub.

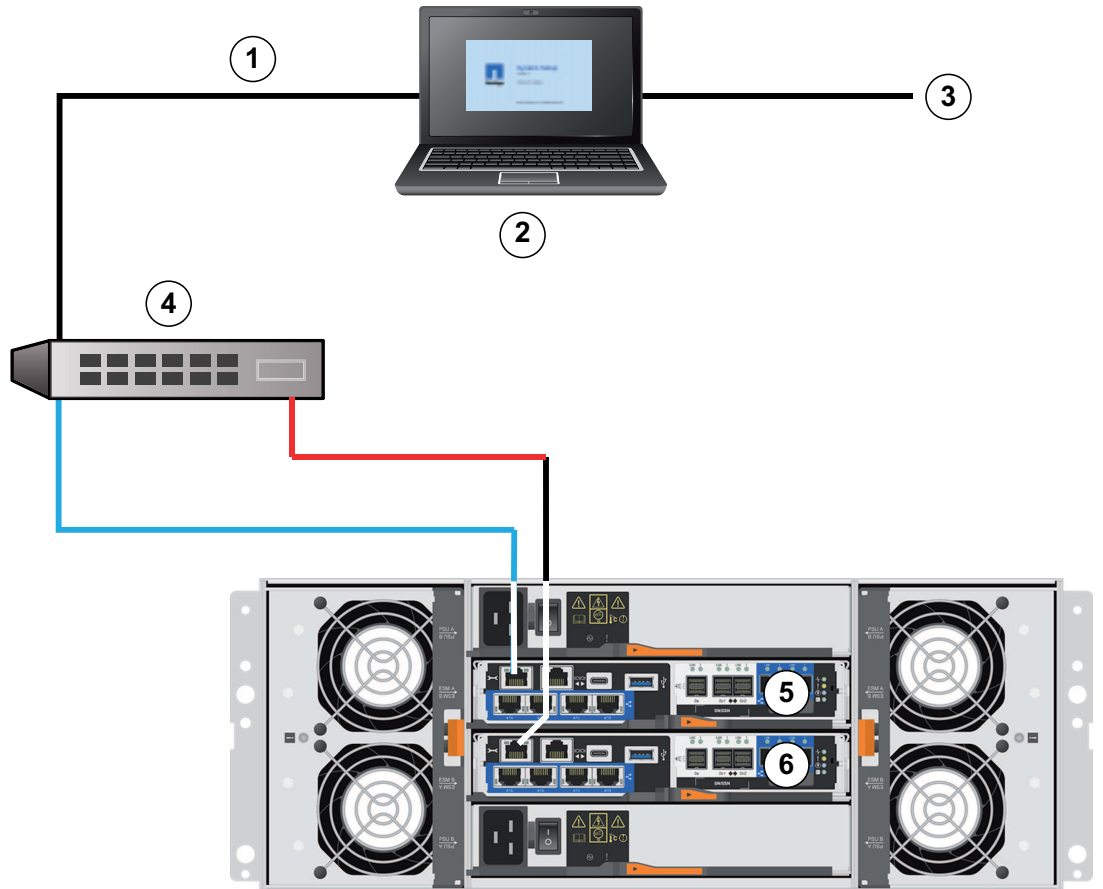

1	Private network	2	Management station or personal computer
3	Local Area Network (LAN)	4	Switch
5	Controller A	6	Controller B

## 5.4 Connecting the units to the power supply

To connect the controller unit and the expansion units to the power supply:

1. Make sure that both power switches on the controller unit are turned off.  
**Note:** If you use expansion units, ensure that their power switches are also turned off.

2. Connect the two power cables of the controller unit to different power distribution units in the cabinet or rack.

**Note:** If you use expansion units, connect the two cables accordingly.

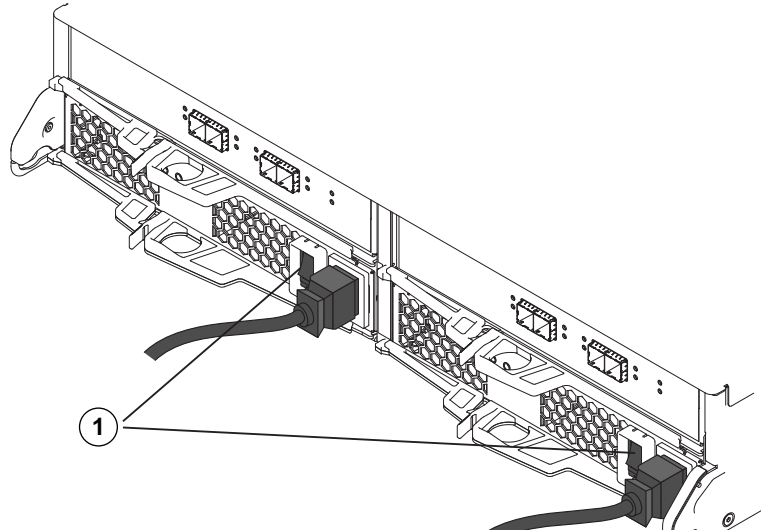

1 = Power switch

## 5.5 Supported connections

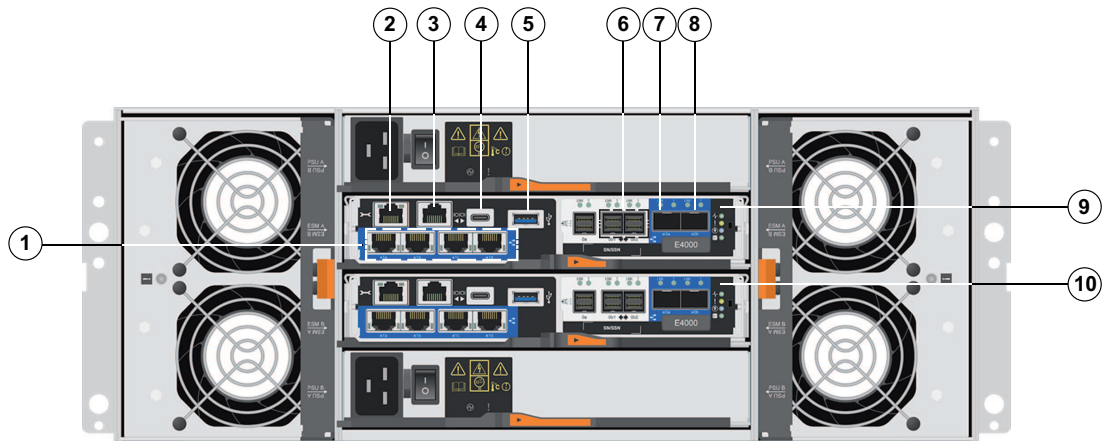

1	iSCSI Base-T ports e1a, e1b, e1c, e1d	2	Management port e0m/BMC
3	Serial port (not used)	4	USB-C serial com port (non-production use only)
5	USB-A port (factory use only)	6	SAS expansion ports 0b1/0b2
7	Optical port e0a	8	Optical port e0b
9	Controller A	10	Controller B (see controller A)

We recommend using the following connection methods:

- Management host to Management ports e0m/BMC of controller A and controller B.
- Two different cabling options for the iSCSI ports:
  - Default: iSCSI, RJ45 Base-T ports e1a, e1b

**Note:**

Port e1a of Controller B is the fallback of port e1a of Controller A and

Port e1b of Controller A is the fallback of port e1b of Controller B

**Note: Do not use ports e1c and e1d!**

- Alternatively: iSCSI, optical ports e0a, e0b

**Note:**

Port e0a of Controller B is the fallback of port e0a of Controller A and

Port e0b of Controller A is the fallback of port e0b of Controller B

## 6 Turning on/off AC power

### 6.1 Turning on AC power

Make sure the Ethernet cable is connected to the management host. The default IP addresses will take three minutes to initialize from the time the network is attached.

To turn on power to the controller unit or the expansion units:

1. Connect the cabinet to the power supply.
2. Turn on the power distribution units of the cabinet.
3. If you have expansion units, turn on their two power switches first.

**Note:** Wait for 2 minutes to allow hard disks to spin up before applying power to the controller unit.

4. Turn on the two power switches on the controller unit and wait approximately 3 minutes.

**Note:**

- The default IP addresses will take approximately 3 minutes to initialize from the time the network is attached.
  - Do not turn off the power switches during the power-on process.
  - The fans are very loud when they first start up. The loud noise during start-up is normal.
5. Check the LEDs and the seven-segment display on the back of each controller.  
**Note:** The seven-segment display shows a repeating sequence (OS, Sd, blank) to indicate that the controller is performing start-of-day processing. After the controller has started, the display shows the tray ID.
  6. If any of the amber LEDs are on, there might be a problem with a component. Confirm you completed the installation steps correctly. If you are unable to resolve the problem, contact your local Technical Support team.

### 6.2 Turning off AC power

We recommend turning off the system when moving the system to another location and upgrading or replacing the hardware, for example.

To turn off power to the controller unit or the expansion units:

1. Stop recording of the cameras and wait for 5 minutes.
2. Ensure there are no background operations in progress.
3. Turn off the controller-unit and wait that all LEDs are off.
4. Turn off the expansion units and wait for 2 minutes to allow hard disks to spin down.
5. Disconnect the cables if required.

## 7 Setting up the storage system

To configure the network settings for all ports, you must use SANtricity System Manager.

SANtricity System Manager is a web-based interface embedded on each controller unit. To access the user interface, you point a browser to the IP address of the corresponding controller unit.

The default IP addresses for controller's management ports e0m/BMC are:

- Controller A: 169.254.128.101
- Controller B: 169.254.128.102
- Subnet mask: 255.255.0.0



### Notice!

DHCP is attempted for the first three minutes of attaching the network cables. If a DHCP lease was not offered within this time, the controllers will use the default addresses.

To access the SANtricity System Manager user interface:

1. Open your browser and enter the following URL: `https://<IPAddress>`.  
**Note:** <IPAddress> is the address of one of the storage array controller units.  
SANtricity System Manager starts.  
**Note:** When SANtricity System Manager starts for the first time on an array that has not been configured yet, you are requested to set an administrator password.
2. In the **Set Administrator Password** field, enter a password. Confirm the password in the **Confirm Password** field, and then click **Set Password** to set the administrator password.

### 7.1 Configuring static IP addresses and network settings for management ports

To configure static IP addresses and network settings for management ports:

1. In SANtricity System Manager, click **Hardware > Controllers & Components**.
2. Select Controller A, then click **Configure management ports**.  
The **Configure management ports** dialog box is displayed.
3. Select the desired management port for which you want to configure the network settings, then click **Next**.
4. Follow the steps on the screen to configure the settings for this port.
5. After you have configured the settings, click **Finish**.  
The respective management port is configured.
6. Repeat the configuration steps for Controller B.

### 7.2 Configuring the iSCSI ports

To configure the iSCSI ports:

1. In SANtricity System Manager, click **Settings > SYSTEM**.
2. In the **iSCSI settings** section, click **Configure iSCSI Ports**.  
The **Configure iSCSI Ports** dialog box is displayed.
3. Select the desired controller for which you want to configure ports, then click **Next**.
4. In the next dialog box, select the desired port and follow the steps on the screen to configure the settings for this port.
5. After you have configured the settings, click **Finish**.  
The respective iSCSI port is configured.
6. Repeat the configuration steps for all desired ports.

## 7.3 Configuring the storage system with BVMS Configuration Client

To configure the storage system with BVMS Configuration Client:

1. In BVMS Configuration Client, in the Device Tree, under VRM Devices, right-click the corresponding Pool, then click **Add DSA E-Series Device**.  
The **Add DSA E-Series Device** dialog box is displayed.
2. Enter the management address and the password, then click **Connect**.
3. After the connection to the controller is established, click **OK** to add the controller to the VRM.  
The controller is added to the VRM and is displayed in the Device Tree under the corresponding pool.
4. Select the DSA E-Series device and open the **Basic Configuration** page.
5. Select the corresponding RAID type and click **Initialize**.
6. After the initialization is finished, activate the BVMS configuration.
7. After the configuration is activated, format the LUNs.

## 7.4 Configuring the storage system with Configuration Manager

To get a basic configuration, do the following steps:

1. Start the Configuration Manager program.
2. Add the device to the system.
3. Create a basic configuration.

### Starting the Configuration Manager program

To start the Configuration Manager program:

- ▶ Double-click the the Configuration Manager icon on the desktop.

### Adding the devices to the system

To add iSCSI devices to the system:

1. Add your VRM server.
2. Click the **My Devices**  tab to display the VRM server in the tree structure.
3. Under VRM > **Storage Systems**, right-click and select **Add iSCSI system...**  
The **Add iSCSI system** dialog box is displayed.
4. Fill in the corresponding information.

### Creating a basic configuration

To create a basic configuration:

1. On the navigation bar, click the **My Devices**  tab.
2. In the tree structure, click the corresponding device, click **Pool x**, click **Storage Systems**, then click the storage system.
3. In the view pane, click the **Basic configuration** tab. The basic configuration settings of the storage system appear.
4. Enter the basic settings of your storage system.
5. Click **Initialize**. An information message box appears.
6. Click **Yes** to confirm that you want to go on with the basic configuration. The **Basic Configuration for the iSCSI system** dialog box appears.  
**Note:** The dialog box shows the status of the configuration process.
7. Click the **Status** tab to display the status of the configuration process.  
Click the **Details** tab to display details about all processes.  
Click **Close** to close the dialog box.



8. Click the **Reload** icon.
9. In the tree structure, right-click the storage system, then click **LUN Assignment....** The **LUN Assignment** dialog box appears.  
**Note:** If multiple iSCSI ports are used, distribute the LUNs equally among the logical iSCSI targets. Do not assign one LUN to multiple logical iSCSI targets.
10. Drag the **Target x** folder from the left side (**Source**) to the right side (**VRM System**), then click **OK**.
11. In the device tree, below the storage system, click **Target x**.  
In the **LUNs** pane to the right, all assigned LUNs appear with the status **Unformatted**.
12. In the **LUNs** pane, click **Select All**, then click **Set**. The LUNs appear with the status **Task format** and a warning message box appears that informs you that formatting a disk will delete all data.
13. Click **Yes** to confirm. The status of the LUNs changes to **Ready**. The LUNs are formatted.

## 8 Maintenance

### 8.1 Replacing a drive in a 60-bay unit

The Recovery Guru in SANtricity System Manager monitors the drives in the unit and can notify you of an impending drive failure or an actual drive failure. When a drive has failed, its amber Attention LED is on. You can hot-swap a failed drive while the unit is receiving I/O operations.

#### Before you begin

- You have a replacement drive that is supported by us for the controller unit, or the expansion unit.
- You have an ESD wristband, or you have taken other antistatic precautions.

#### About this procedure

Use this procedure to replace a drive in the following controller units or expansion units:

Type	Number of drives	Type of drives
60-bay controller unit	60	3.5-inch SAS drives in carriers
60-bay expansion unit	60	

The 60-bay controller unit and the 60-bay expansion unit consist of 5 drive drawers that each contain 12 drive slots. Drive drawer 1 is at the top, and drive drawer 5 is at the bottom. The drives are numbered from 0 to 11 in each drive drawer.

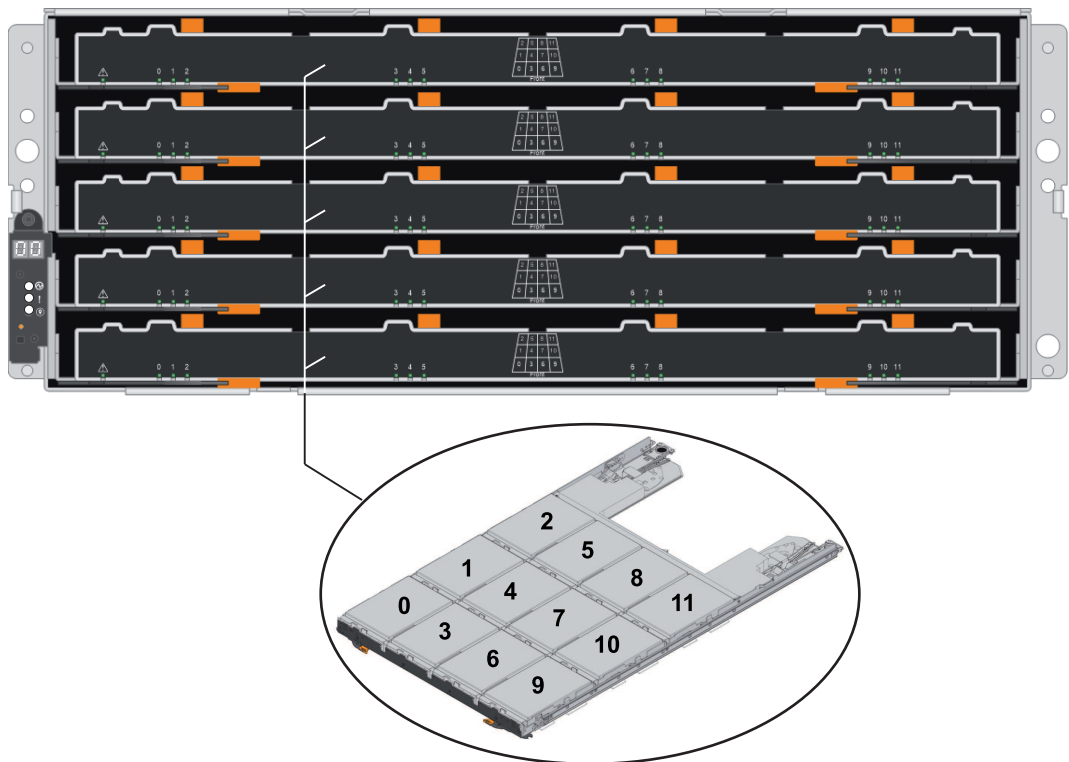

#### Rules for handling drives

The drives are fragile. Improper drive handling is a leading cause of drive failure. Follow these rules to avoid damaging the drives in your unit:

- Prevent electrostatic discharge (ESD)
  - Keep the drive in the ESD bag until you are ready to install it.

- Do not insert a metal tool or knife into the ESD bag. Open the ESD bag by hand or cut the top off with a pair of scissors.
- Keep the ESD bag and any packing materials in case you must return a drive later.
- Always wear an ESD wrist strap grounded to an unpainted surface on your storage enclosure chassis. If a wrist strap is unavailable, touch an unpainted surface on your storage enclosure chassis before handling the drive.
- Handle drives carefully
  - Always use two hands when removing, installing, or carrying a drive.
  - Never force a drive into a unit. Use gentle, firm pressure to completely engage the drive latch.
  - Place drives on cushioned surfaces, and never stack drives on top of each other.
  - Do not bump drives against other surfaces.
  - Before removing a drive, unlatch the handle and wait 30 seconds for the drive to spin down.
  - Always use approved packaging when shipping drives.
- Avoid magnetic fields
  - Keep drives away from magnetic devices. Magnetic fields can destroy all data on the drive and cause irreparable damage to the drive circuitry.

### 8.1.1

#### Preparing to replace a drive

Before replacing a drive, check the Recovery Guru in SANtricity System Manager and complete any prerequisite steps. Then, you can locate the failed drive.

To locate the failed drive:

1. If the Recovery Guru in SANtricity System Manager has notified you of an impending drive failure, but the drive has not yet failed, follow the instructions in the Recovery Guru to fail the drive.
2. If needed, use SANtricity System Manager to confirm you have a suitable replacement drive.
  - Select **Hardware**.
  - Select the failed drive on the unit graphic.
  - Click the drive to display the context menu, then select **View settings**.
  - Confirm that the replacement drive has a capacity equal to or greater than the drive you are replacing and that it has the features you expect.  
For example, do not attempt to replace a hard disk drive (HDD) with a solid-state disk (SSD). Similarly, if you are replacing a secure-capable drive, make sure the replacement drive is also secure-capable.
3. If needed, use SANtricity System Manager to locate the drive within the unit.
  - If the unit has a bezel, remove it so you can see the LEDs.
  - From the drive's context menu, select **Turn on locator light**.  
The drive drawer's amber Attention LED blinks so you can open the correct drive drawer to identify which drive to replace.

**Note:** The drive drawer Attention LEDs are on the left side in front of each drive, with an

attention icon on the drive handle just behind the LED.



①

1 = Attention LED on drive drawer

- Unlatch the drive drawer by pulling on both levers.
- Using the extended levers, carefully pull the drive drawer out until it stops.
- Look at the top of the drive drawer to find the Attention LED in front of each drive.



1 = Attention LED light on for the drive on the top right side.

## 8.1.2

### Removing a drive

When removing a drive from a 60-bay controller unit or a 60-bay expansion unit, you must lift the drive partly out of the drawer and wait for the drive to spin down. Then, you can remove the drive completely.

Before you begin:

- You have an ESD wristband, or you have taken other antistatic precautions.
- You have reviewed the *Rules for handling drives*, page 38.

To remove a drive:

1. Unpack the replacement drive, and set it on a flat, static-free surface near the unit. Save all packing materials for the next time you need to send a drive back.
2. If you have not already done so, release the drive drawer levers from the center of the appropriate drive drawer by pulling both towards the sides of the drawer.
3. If you have not already done so, carefully pull on the extended drive drawer levers to pull out the drive drawer to its full extension without removing it from the enclosure.

4. Gently pull back the orange release latch that is in front of the drive you want to remove. The cam handle on the drive springs open partially, and the drive is released from the drawer.



1 = Orange release latch

5. Open the cam handle, and lift out the drive slightly.
6. Wait 30 seconds.
7. Use the cam handle to lift the drive from the unit.

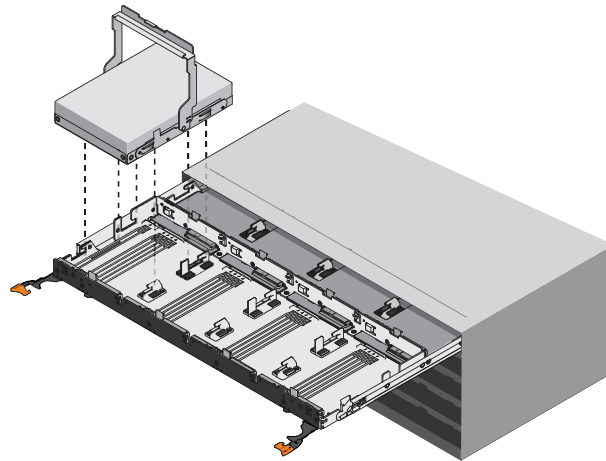

8. Place the drive on an antistatic, cushioned surface away from magnetic fields.
9. Wait 30 seconds for the software to recognize that the drive has been removed.



**Notice!**

If you accidentally remove an active drive, wait at least 30 seconds, and then reinstall it. For the recovery procedure, refer to the storage management software.

**8.1.3**

**Installing a drive**

Install the replacement drive as soon as possible after removing the failed drive. Otherwise, there is a risk that the equipment might overheat.

To install a drive:

1. Raise the cam handle on the new drive to vertical.

- Align the two raised buttons on each side of the drive carrier with the matching gap in the drive channel on the drive drawer.



1 = Raised button on the right side of the drive carrier

- Lower the drive straight down, and then rotate the cam handle down until the drive snaps into place under the orange release latch.
- Carefully push the drive drawer back into the unit.



**Note:** Possible loss of data access: Never slam the drawer shut. Push the drawer in slowly to avoid jarring the drawer and causing damage to the unit.

- Close the drive drawer by pushing both levers towards the center. The green Activity LED for the replaced drive on the front of the drive drawer comes on when the drive is inserted correctly.

**Note:** Depending on your configuration, the controller might automatically reconstruct data to the new drive. If the unit uses hot spare drives, the controller might need to perform a complete reconstruction on the hot spare before it can copy the data to the replaced drive. This reconstruction process increases the time that is required to complete this procedure.

### 8.1.4

#### After replacing a drive

After replacing a drive, you must confirm that the new drive is working correctly.

To confirm that the new drive is working correctly:

- Check the Activity LED and the Attention LED on the drive you replaced.

LED status	Description
The Activity LED is on or blinking, and the Attention LED is off.	The new drive is working correctly.
The Activity LED is off.	The drive might not be installed correctly. Remove the drive, wait 30 seconds, and then reinstall it.
The drive drawer's Attention LED is on.	The new drive might be defective. Replace it with another new drive.

LED status	Description
	<b>Note:</b> When you first insert a drive, its Attention LED might be on. However, the LED should go off within a minute.

2. If the Recovery Guru in SANtricity System Manager still shows an issue, select **Recheck** to ensure the problem has been resolved.
3. If the Recovery Guru indicates that drive reconstruction did not start automatically, start reconstruction manually, as follows:  
**Note:** Perform this operation only when instructed to do so by technical support or the Recovery Guru.
  - Select **Hardware**.
  - Click the drive that you replaced.
  - From the drive's context menu, select **Reconstruct**.
  - Confirm that you want to perform this operation.When the drive reconstruction completes, the volume group is in an optimal state.
4. As required, reinstall the bezel on the front of the unit.









**IQSIGHT B.V.**

Achtseweg Zuid 173  
5651 GW Eindhoven  
The Netherlands

**[www.iqsight.com](http://www.iqsight.com)**

© IQSIGHT 2026



202604241605